

Quest 506

Installation, Operation and Maintenance Instructions

– Read and Save These Instructions –

This manual is provided to acquaint you with the dehumidifier so that installation, operation and maintenance can proceed successfully. Ultimate satisfaction depends on the quality of installation and a thorough understanding of this equipment. The dehumidifier is built around tested engineering principles and has passed a thorough inspection for quality of workmanship and function.

Features:

- Industry-leading efficiency, most efficient on the market today
- Patented, refrigeration system
- High-efficiency, long-life impeller fan
- Quiet operation
- Superior air filtration (MERV-13 standard)
- Auto-restart after power outages
- Environmentally friendly R410A refrigerant
- Low voltage control

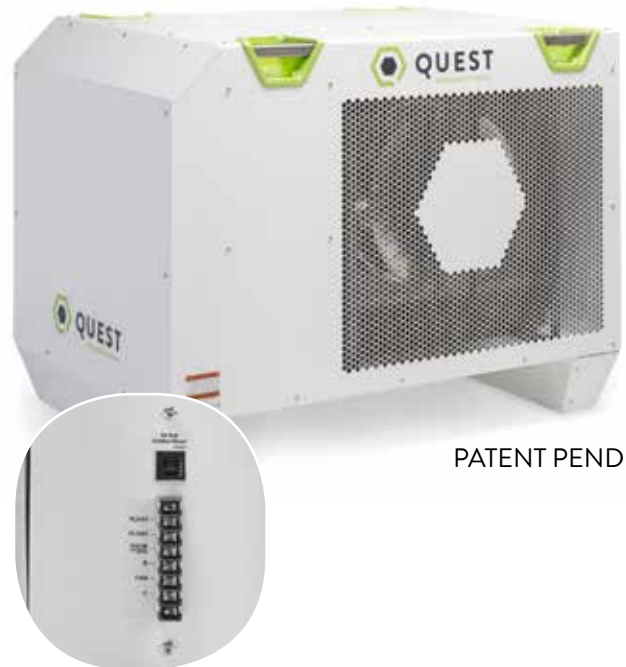

PATENT PENDING

Water Removal Rates (Pints/Day) @ 80°F 60% (AHAM)

Dehumidifier	Pints Removed	Gallons/Liters
Quest 506	506	63.2/239.4



4201 Lien Rd
Madison, WI 53704
www.QuestHydro.com

Toll-Free 1-877-420-1330
info@QuestHydro.com

Table of Contents

Safety Precautions 3

1. Intended Application 4

2. Registrations 4

3. Specifications 4

4. Installation 5

 4.1 Location 5

 4.2 Electrical Requirements..... 5

 4.3 Condensate Removal 5

 4.4 Hanging 6

5. Controls 7

 5.1 Humidity Control 7

 5.2 24VAC Wiring..... 7

 5.2A Deh 3000R 8

 5.2B Honeywell Remote Humidistat 8

6. Maintenance 8

 6.1 Standard Air Filter 9

7. Service 9

 7.1 Warranty 9

 7.2 Technical description..... 9

8. Ducting Guidelines 9

 Wiring Diagram..... 10

Service Parts List 11

Optional Parts List 11

Warranty 12

Safety Precautions

Read the installation, operation and maintenance instructions carefully before installing and operating this device. Proper adherence to these instructions is essential to obtain maximum benefit from your **Quest 506** Dehumidifier.

READ AND SAVE THESE INSTRUCTIONS

- The device is designed to be installed **INDOORS IN A SPACE THAT IS PROTECTED FROM RAIN AND FLOODING.**
- Install the unit with space to access side panels for maintenance and service. **DO NOT INSTALL UNIT WITH THE SERVICE PANELS INACCESSIBLE.**
- Avoid directing the discharge air at people, or over the water in pool areas.
- If used near a pool, spa or water; be certain there is **NO** chance the unit could fall into the water, be splashed and that it is plugged into an outlet that is a **GROUND FAULT INTERRUPT** protected circuit.
- **DO NOT** use the device as a bench or table.
- **DO NOT** place the device directly on structural members. Provide vibration isolation in order to minimize operational vibration and/or noise.
- A drain pan **MUST** be placed under the unit if installed above a living area or above an area where water leakage could cause damage
- Never operate a unit with a damaged power cord. If the power cord is damaged it must be replaced by the manufacturer, its service agent, or similarly qualified person in order to avoid a hazard.
- Make all electrical connections in accordance with the current edition of the **NEC ANSI/NFPA 70** and any national and local codes or ordinances that may apply.
- Do not obstruct the air intake and exhaust. Maintain a 4ft clearance around the air intake and exhaust.
- This appliance is not intended for use by persons (including children) with reduced physical, sensory or mental capabilities, or lack of experience and knowledge, unless they have been given supervision or instruction concerning use of the appliance by a person responsible for their safety. Children should be supervised to ensure that they do not play with the appliance.
- Not intended for use at altitudes over 2000m.

1. Intended Application for Quest 506 Dehumidifier

The Quest 506 Dehumidifier is designed to operate in temperatures between 56° and 95°F.

In order to efficiently control humidity levels, the area in which the dehumidifier is to be operated must be free of water intrusion or excessive fresh (outside) air infiltration. Before installing the Quest 506 Dehumidifier, water intrusion and air infiltration problems should be addressed or noted in calculations.

2. Registrations

The Quest 506 Dehumidifier units conform to unified standard UL 60335-2-40.

3. Specifications @ 80°F/60% RH

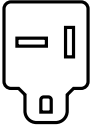
Unit:	Quest 506 4036600	
Power (Watts):	2700	
Supply voltage:	220-240 VAC - 1 Phase - 60 Hz.	
Current Draw (Amps):	11.0	
Rated Current Draw (Amps): (104°F 36%)	13.6	
Energy Factor (L/kWh):	3.8	
Operating Temp:	56°F Min - 95°F Max	
Water Removal (Pints/Day):	506	
Efficiency (Pints/kWh):	8.1	
Air Filter (MERV-13): (2)	Size: 18" x 20" x 2"	
Power Cord:	 14ga 10', NEMA 6-20P	
Drain Connection:	3/4 Threaded NPT	
Refrigerant Type:	R410A	
Refrigerant Amount:	4lb. 8oz.	
Dimensions:	Unit	Shipping
Width:	28.9"	36"
Height:	33.8"	40"
Length:	44.7"	48"
Weight:	280 lbs	340 lbs

4. Installation

4.1 Location

The Quest 506 Dehumidifier can be installed in a variety of locations to meet the owner's needs as listed below. In all cases keep the following cautions in mind:

- It is designed to be installed **INDOORS IN A SPACE THAT IS PROTECTED FROM RAIN AND FLOODING.**
- Install the unit with space to access side panel for maintenance and service. **DO NOT INSTALL UNIT WITH ACCESS PANEL INACCESSIBLE.**
- Avoid discharging the air directly at people, or over the water in pool areas.
- Be certain there is **NO** chance the unit could fall into water or be splashed and that it is plugged into a **GROUND FAULT INTERRUPTER.**
- **DO NOT** use the Quest 506 Dehumidifier as a bench or table.
- **DO NOT** place the Quest 506 Dehumidifier directly on structural members. Provide vibration isolation in order to minimize operational vibration and/or noise.
- A drain pan **MUST** be placed under the unit if installed above an area where water leakage could cause damage.

4.2 Electrical Requirements



WARNING! Electrical shock Hazard: Electrical power must be present for some tests. These tests should be performed by a qualified service person.

The Quest 506 Dehumidifier plugs into NEMA rated Receptacles. The amp draws for each unit under normal operating conditions are listed on page 4. A ground fault interrupter protected circuit is required.

Install the remote control panel in a central area of the structure where it will sense the relative humidity of the structure accurately. Do not install the control panel where it may not accurately sense the relative humidity such as near HVAC supply registers, near exterior doors, or near a pool or spa. The installer must supply the wiring between the Quest 506 Dehumidifier and the control panel. Be sure to safely route the control wiring to prevent damage during installation. Be careful not to cross the wires when connecting the Quest 506 Dehumidifier and the remote control panel.

The remote controls of the Quest 506 Dehumidifier are powered by a low voltage circuit (24 VAC) and must **NEVER** contact or be connected to a high voltage circuit. The control terminals and remote control are labeled and numbered to prevent confusion. Be sure to consult the electrical schematic in this manual or inside the access panel of the Quest 506 Dehumidifier before making the control connections.



WARNING! Damaged power cords can only be replaced with one by the unit manufacturer.

4.3 Condensate Water Removal

Condensate drains by gravity via the drain port. Use 3/4" male NPT PVC pipe. Route the drain pipe through provided trap to drain. An optional condensate pump kit may be installed if a lift is required to dispose of the condensate. The condensate pump kit can be ordered directly from the factory. See the optional parts list for information on the kit.

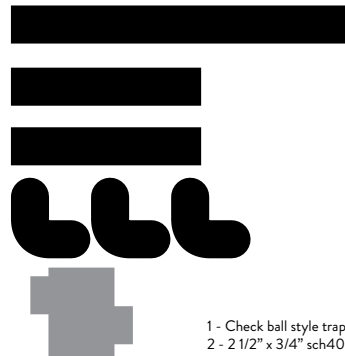
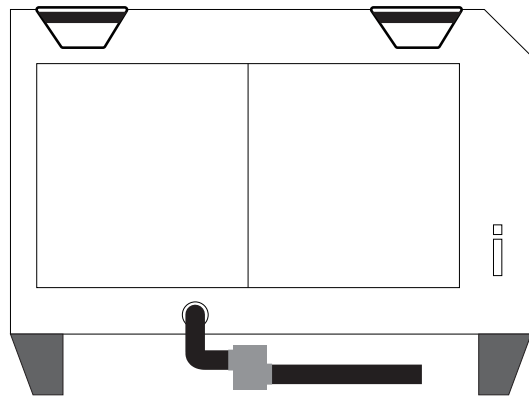

- 1 - Check ball style trap
- 2 - 2 1/2" x 3/4" sch40 pvc pipe
- 1 - 5" x 3/4" sch40 pvc pipe
- 2 - 90° glue in elbow 3/4"
- 1 - Barb adapter

4.4 Hanging Diagram

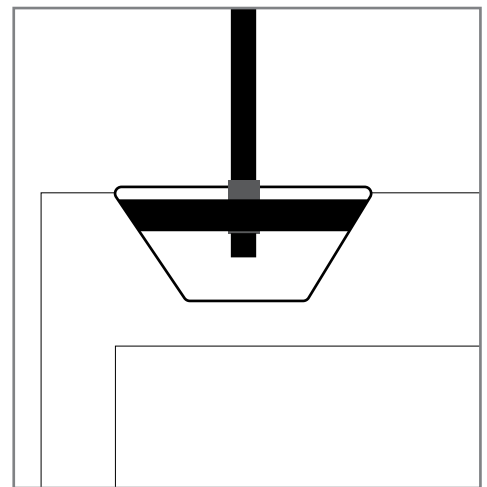

Parts Needed: 4 pieces 3/8" threaded rod
4 - 3/8" threaded jam nuts

Instructions: Thread jam nut onto threaded rod
Screw threaded rod into handles
Tighten jam nuts to handle to prevent movement

! WARNING! Hanging installation must meet all state and local codes.

! WARNING! Installation should be done by a qualified agency in accordance with these instructions. The qualified service agency installing this high efficiency refrigeration system is responsible for the installation.

! WARNING! Check the supporting structure to be used to verify that it has sufficient load carrying capacity to support the weight of the unit. Suspend the unit only from the threaded nut retainers. Do NOT suspend from the cabinet. Recommended maximum hanger rod is 6 feet (1.8m)

5. Control Options

The Quest 506 Dehumidifier can be controlled by an external remote humidistat through a 24V terminal block.

5.1 Humidity Control

A 24VAC signal is sent by the remote humidistat signals the fan or fan and compressor to actuate.

Quest Control Options:

- DEH 3000
- Honeywell Humidistat
- Any 24V signal to Dehumidify



CAUTION! **Low Voltage Hazard**
Can cause equipment damage
Disconnect before beginning installation.

5.2 24VAC Wiring

The terminal block, circuit breaker and power switch are located on the intake side of the unit.

FLOAT: {External low voltage float switch. Use a normally closed switch. If no float switch is use in the system

FLOAT: leave the jumper connected to the terminal block.}

DEHU: Dehumidificaton (compressor and fan operation).

R: 24VAC output

FAN: Fan operation only.

C: 24VAC neutral (common)

Note:

Outer screw are not used for wiring.

Be sure external power control switch is on. System will not activate if switch is off.

External devices can be powered between 24V/COM (20VA max).

24V circuit is protected by circuit breaker

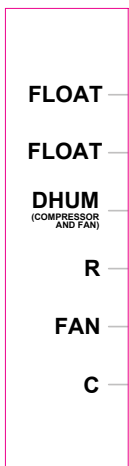

5.2A DEH 3000 Control

QUEST DEH 3000R CONTROL WIRING DIAGRAM

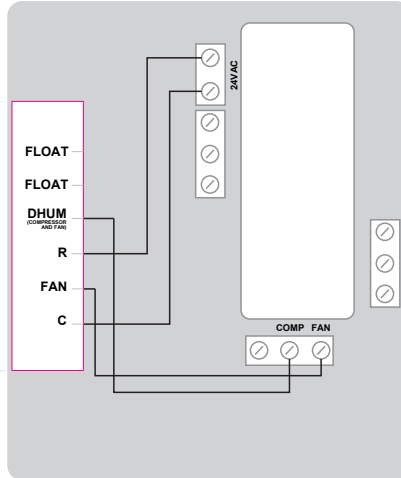

5.2B HONEYWELL Remote Humidistat

HONEYWELL REMOTE HUMIDISTAT WIRING DIAGRAM

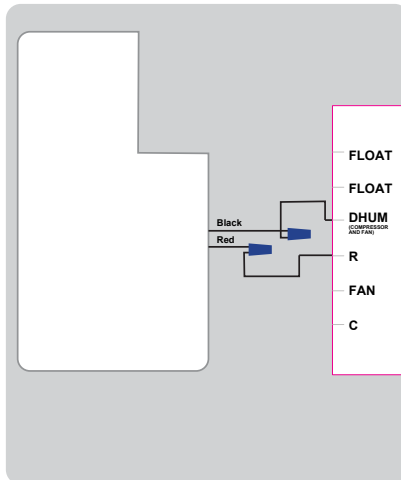

6. Maintenance



WARNING!

Do not operate the unit without the filter or with a less effective filter. The heat exchange coils inside the unit could become clogged and require disassembly to clean. Filter non-compliance invalidates the product warranty.

6.1 Standard Air Filter

The Quest 506 Dehumidifier ships with a standard MERV 13 efficient pleated fabric filter. This filter should be checked every six months. Operating the unit with a dirty filter will reduce dehumidifier capacity and efficiency and may cause the compressor to cycle off and on unnecessarily on the defrost control.

To access the air filter, the filter should be readily visible and can be removed by pulling it straight out of the Quest 506 Dehumidifier.

We recommend changing the filter at least with every grow cycle.

7. Service



WARNING!

Servicing the Quest 506 with its high pressure refrigerant system and high voltage circuitry presents a health hazard which could result in death, serious bodily injury, and/or property damage. Only qualified service people should service this unit.

7.1 Warranty

A warranty certificate has been enclosed with this unit; read it before any repair is initiated. If a warranty repair is required, call the factory first at 1-877-420-1330 for warranty claim authorization and technical assistance.

7.2 Technical Description

The Quest 506 Dehumidifier uses a refrigeration system similar to an air conditioner's to remove heat and moisture from incoming air, and add heat to the air that is discharged.

Hot, high-pressure refrigerant gas is routed from the compressor to the condenser coil. The refrigerant is cooled and condensed by giving up its heat to the air that is about to be discharged from the unit. The refrigerant liquid then passes through a filter/drier and expansion drier which causes the refrigerant pressure and temperature to drop. It next enters the evaporator coil where the cool refrigerant absorbs heat from the incoming air and evaporates.

The compressor evacuates the cool refrigerant vapor from the evaporator and compresses it to a high pressure and temperature to repeat the process.

8. Ducting Guidelines



CAUTION! Quest 506 is intended for use in statics under .25"WG.

- Ducting either the intake or exhaust use a minimum of two 12" diameter round ducts minimum.
- Grills or diffusers on the duct ends must not excessively restrict airflow.
- Effective dehumidification may require ducting to be branched to isolated or stagnant flow areas. Be sure to use appropriate size duct branches to maintain proper feed throughout the ducting system.
- System control should be placed remotely from the dehumidifier in a central location.
- Intake and exhaust ducting should have a minimum of 4 feet from the unit before any turns.



CAUTION!

Do not connect with a static pressure greater than +.25"wg. Contact technical support for additional details.

Wiring Diagram of the Quest 506 Dehumidifier

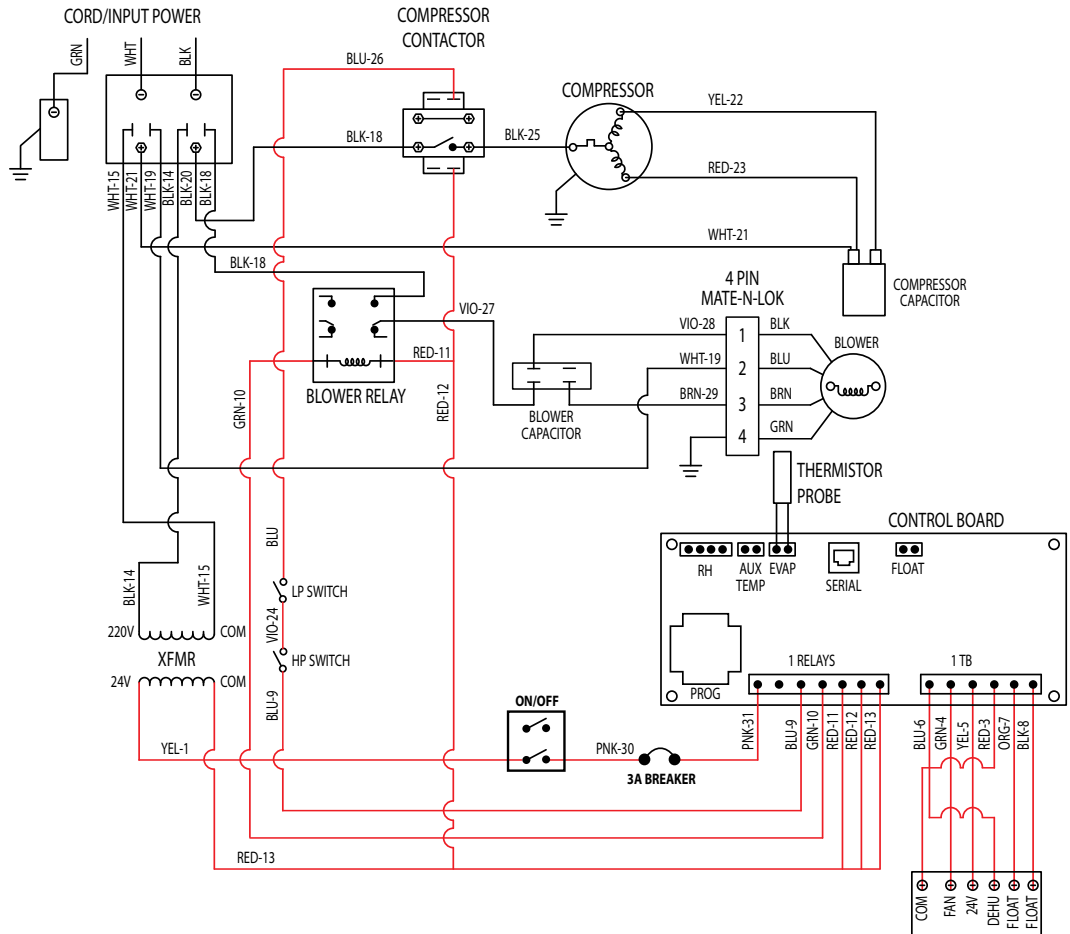

P/N 4038213

Service Parts List

Item	Part No	Description	Item	Part No	Description
1	4029507	CONTROL,HIGH PRESSURE	15	4037704-02	COIL,CONDENSER
2	4029508	CONTROL,LOW PRESSURE	16	4037707	TXV,3 TON
3	4029575	RELAY	17	4037708	FAN,MOTORIZED IMPELLER
4	4031101	CONTACTOR	18	4037728	CORD
5	4031406	TRANSFORMER	19	4038135	HANDLE,POCKET
6	4035949-06	CAPACITOR, COMP.	20	4038136	BEZEL,HANDLE
7	4036164-20	TUBE,CU,CPLRY	21	4038178	WIRE HARNESS
8	4036559	CIRCUIT BREAKER	22	4038079	LUG,GROUND
9	4036965	CLAMP,CAPACITOR	23	4038219	FOOT,RUBBER,1.25" DIA
10	4037221-06	CAPACITOR	24	4038225-01	BRACKET,FOOT,RIGHT
11	4037699	THERMISTOR	25	4038226-01	BRACKET,FOOT LEFT
12	4037701	CPRSR	26	4038215	BLOCK, WIRING
13	4037702	FILTER,DRIER	27	4038502	CONTROL ASSY
14	4037703-04	COIL,EVAP	28	4038233	FILTER
			29	4038644	KIT, DRAINTRAP

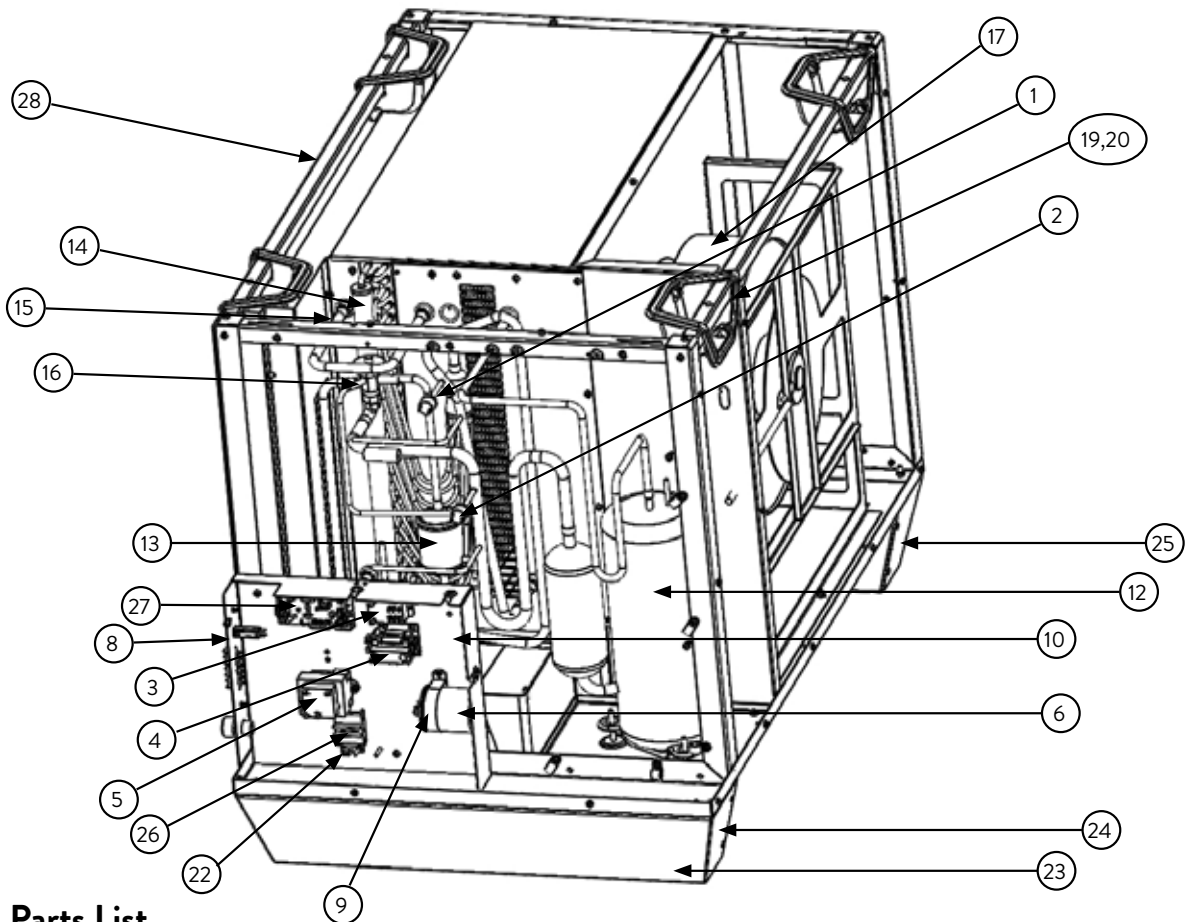

Optional Parts List

PART NO.	QTY.	DESCRIPTION	PART NO.	QTY.	DESCRIPTION
4020175	1	Controller, Humidity	4038643	1	Kit, Pump
4028531	1	DEH 3000R Control, Remote	4038642	1	Kit, Intake Duct
			4038641	1	Kit, Exhaust Duct



Quest 506 Dehumidifier Limited Warranty

WARRANTOR:

Therma-Stor LLC
4201 Lien Rd
Madison, WI 53704
Telephone: 1-800-533-7533

WHO IS COVERED: This warranty extends only to the original end-user of the Quest 506 Dehumidifier dehumidifier, and may not be assigned or transferred.

FIRST YEAR WARRANTY: Therma-Stor LLC warrants that, for one (1) year the Quest 506 Dehumidifier dehumidifier will operate free from any defects in materials and workmanship, or Therma-Stor LLC will, at its option, repair or replace the defective part(s), free of any charge.

SECOND THROUGH FIFTH YEAR WARRANTY: Therma-Stor LLC further warrants that for a period of five (5) years, the condenser, evaporator, and compressor of the Quest 506 Dehumidifier dehumidifier will operate free of any defects in material or workmanship, or Therma-Stor LLC, at its option, will repair or replace the defective part(s), provided that all labor and transportation charges for the part(s) shall be borne by the end-user.

END-USER RESPONSIBILITIES: Warranty service must be performed by a Servicer authorized by Therma-Stor LLC. If the end-user is unable to locate or obtain warranty service from an authorized Servicer, he should call Therma-Stor LLC at the above number and ask for the Therma-Stor LLC Service Department, which will then arrange for covered warranty service. Warranty service will be performed during normal working hours.

The End-user must present proof of purchase (lease) upon request, by use of the warranty card or other reasonable and reliable means. The end-user is responsible for normal care. This warranty does not cover any defect, malfunction, etc. resulting from misuse, abuse, lack of normal care, corrosion, freezing, tampering, modification, unauthorized or improper repair or installation, accident, acts of nature or any other cause beyond Therma-Stor LLC's reasonable control.

LIMITATIONS AND EXCLUSIONS: If any Quest 506 Dehumidifier Dehumidifier part is repaired or replaced, the new part shall be warranted for only the remainder of the original warranty period applicable thereto (but all warranty periods will be extended by the period of time, if any, that the Quest 506 Dehumidifier Dehumidifier is out of service while awaiting covered warranty service).

UPON THE EXPIRATION OF THE WRITTEN WARRANTY APPLICABLE TO THE Quest 506 Dehumidifier DEHUMIDIFIER OR ANY PART THEREOF, ALL OTHER WARRANTIES IMPLIED BY LAW, INCLUDING MERCHANTABILITY AND FITNESS FOR A PARTICULAR PURPOSE, SHALL ALSO EXPIRE. ALL WARRANTIES MADE BY THERMA-STOR LLC ARE SET FORTH HEREIN, AND NO CLAIM MAY BE MADE AGAINST THERMA-STOR LLC BASED ON ANY ORAL WARRANTY. IN NO EVENT SHALL THERMA-STOR LLC, IN CONNECTION WITH THE SALE, INSTALLATION, USE, REPAIR OR REPLACEMENT OF ANY Quest 506 Dehumidifier DEHUMIDIFIER OR PART THEREOF BE LIABLE UNDER ANY LEGAL THEORY FOR ANY SPECIAL, INDIRECT OR CONSEQUENTIAL DAMAGES INCLUDING WITHOUT LIMITATION WATER DAMAGE (THE END-USER SHOULD TAKE PRECAUTIONS AGAINST SAME), LOST PROFITS, DELAY, OR LOSS OF USE OR DAMAGE TO ANY REAL OR PERSONAL PROPERTY.

Some states do not allow limitations on how long an implied warranty lasts, and some do not allow the exclusion or limitation of incidental or consequential damages, so one or both of these limitation may not apply to you.

LEGAL RIGHTS: This warranty gives you specific legal rights, and you may also have other rights which vary from state to state.